

Hamilton Beach®

Coffeemaker

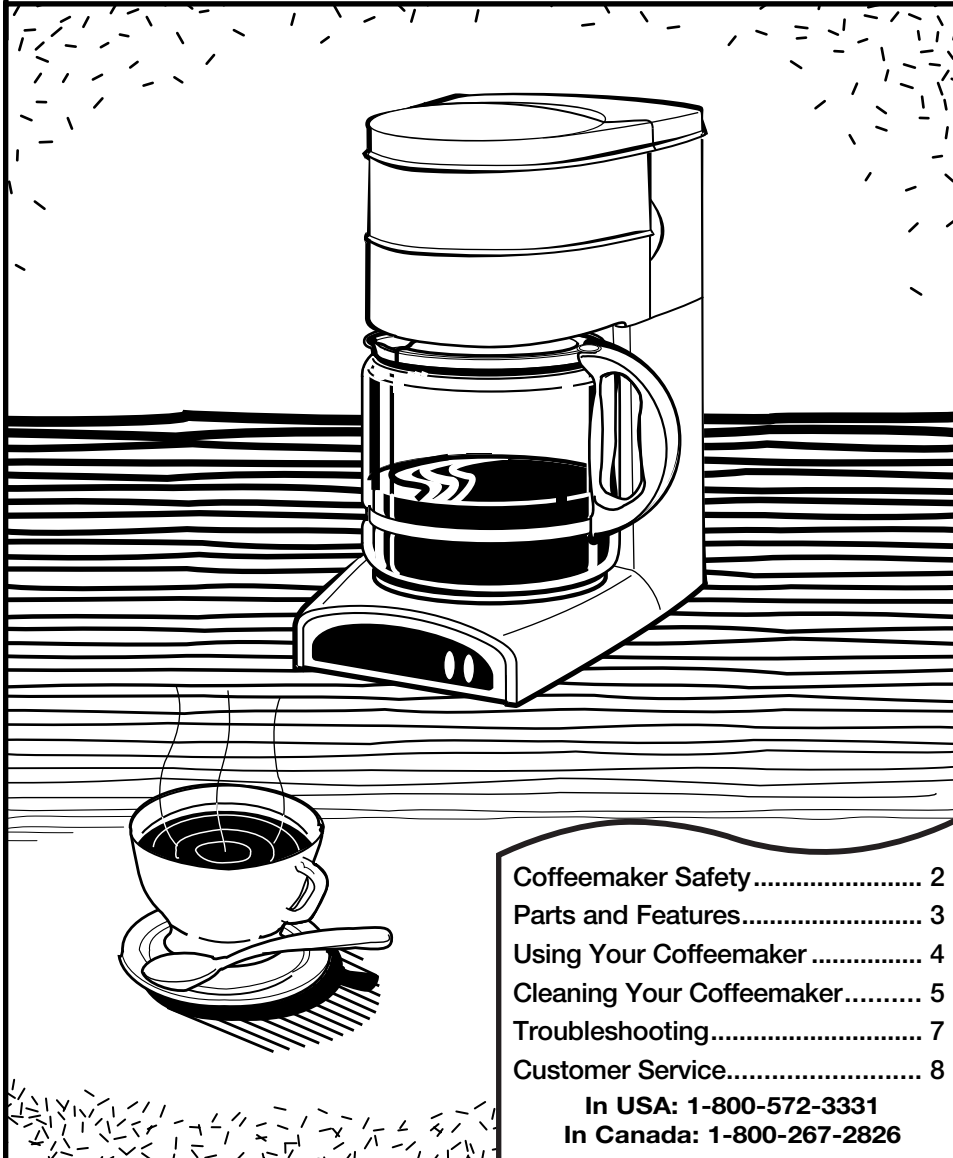

Coffeemaker Safety	2
Parts and Features.....	3
Using Your Coffeemaker	4
Cleaning Your Coffeemaker.....	5
Troubleshooting.....	7
Customer Service.....	8

In USA: 1-800-572-3331
In Canada: 1-800-267-2826

Coffemaker Safety

IMPORTANT SAFEGUARDS

When using electrical appliances, basic safety precautions should always be followed to reduce the risk of fire, electric shock, and/or injury to persons, including the following:

1. Read all instructions.
2. Do not touch hot surfaces. Use handles or knobs. Care must be taken, as burns can occur from touching hot parts or from spilled, hot liquid.
3. To protect against electric shock, do not place cord, plug or coffemaker in water or other liquid.
4. Close supervision is necessary when any appliance is used by or near children.
5. Unplug from outlet when the coffemaker is not in use and before cleaning. Allow to cool before putting on or taking off parts and before cleaning the appliance.
6. Coffemaker must be operated on a flat surface away from the edge of counter to prevent accidental tipping.
7. Do not operate any appliance with a damaged cord or plug, or after the appliance malfunctions or is dropped or damaged in any manner. Call our toll-free customer service number for information on examination, repair or electrical or mechanical adjustment.
8. The use of accessory attachments not recommended by Hamilton Beach/Proctor-Silex, Inc. may result in fire, electrical shock or personal injury.
9. Do not use outdoors.
10. Do not let cord hang over edge of table or counter or touch hot surfaces, including stove.
11. The carafe is designed for use with this coffemaker. It must never be used on a range top or in a microwave oven.
12. Do not set a hot carafe on a wet or cold surface.
13. Do not use a cracked carafe or one with loose or weakened handle.
14. Do not clean carafe with abrasive cleansers or steel wool pads, or other abrasive material.
15. Be certain carafe lid is securely in place during brew cycle and when pouring coffee, do not use force when placing lid on carafe.
16. Do not place coffemaker on or near a hot gas or electric burner or in a heated oven.
17. To disconnect coffemaker, turn controls to OFF, then remove plug from wall outlet.
18. Warning: To reduce the risk of fire or electric shock, do not remove the bottom cover. No user serviceable parts are inside. Repair should be done by authorized service personnel only.
19. Do not use appliance for other than intended use.

SAVE THESE INSTRUCTIONS!

Consumer Safety Information

This appliance is equipped with a grounded-type 3-wire cord (3-prong plug). This plug will only fit into an electrical outlet made for a 3-prong plug. This is a safety feature. If the plug should fail to fit, contact an electrician to replace the obsolete outlet. Do not attempt to defeat the safety purpose of the grounding pin, part of the 3-prong plug.

This appliance has a short cord to reduce hazards of becoming entangled or tripping over a longer cord. A grounded-type 3 wire

extension cord may be used if the electrical rating of the extension cord is equal to or greater than the rating of the coffemaker. Use only an extension cord rated 15 amperes or greater. Care must be taken to arrange the extension cord so that it will not drape over countertop or tabletop where it can be pulled on by children or tripped over.

To avoid an electrical circuit overload, do not use another appliance on the same circuit with your coffemaker.

Parts and Features

1. Reservoir
2. Carafe
3. Keep Hot Plate
4. Swing Open Filter Basket

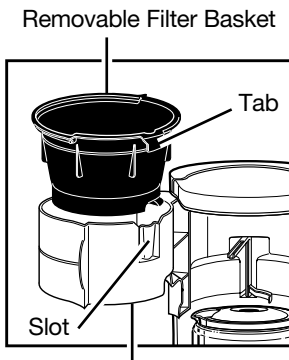
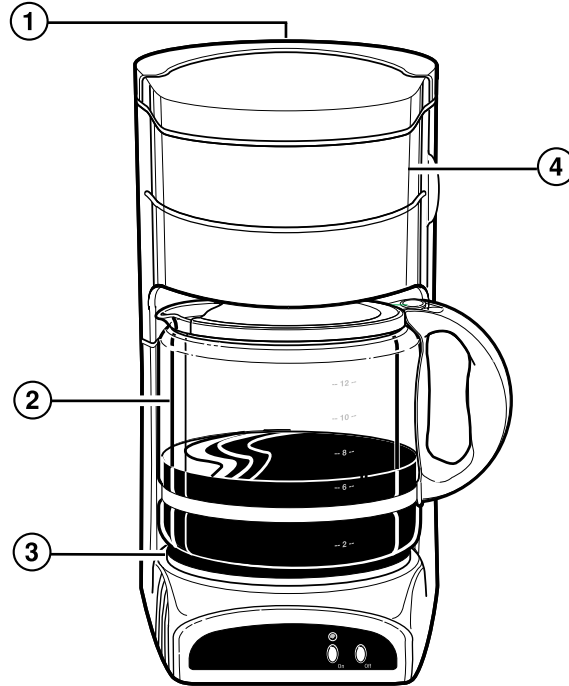

Swing Open Filter Basket Holder
(not removable)

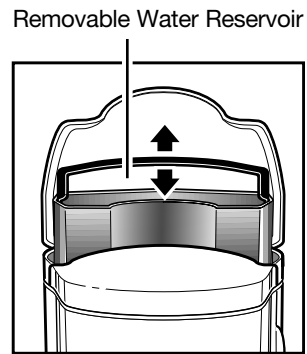

Using Your Coffeemaker

To Make Coffee

1. Plug in coffeemaker.
2. Before first use, wash the carafe, then run one full carafe of clean water through a complete cycle by following steps 7 through 11.
3. To make coffee, swing open filter basket holder and remove filter basket. Place disposable paper filter in filter basket. Use a good quality cupcake (basket) style filter, 8 to 12 cup size. A permanent filter may also be used.
4. For each cup of coffee being made, place one level measuring tablespoon of ground coffee into filter.
5. Place the filter basket in the filter basket holder by aligning tab and slot.
6. Close filter basket holder, making sure it is securely in place.
7. Fill carafe with the desired amount of cold water. Flip open reservoir cover and pour into reservoir or lift out the removable reservoir and fill with water to the desired level. Carefully replace the removable reservoir in the coffeemaker. Make sure it is fully seated for proper water flow. Flip reservoir cover down to close.
8. Place carafe with carafe lid attached on Keep-Hot Plate.
9. Turn coffeemaker on.
10. The coffeemaker will shut off in two hours.
11. When finished turn off and unplug.

How to Brew Good Coffee

Quality coffee comes from quality ingredients. For the best coffee, you should start with freshly ground coffee from freshly roasted beans. The beans can be purchased and stored in an airtight container in the freezer. Just prior to brewing, remove the amount needed and grind the beans. Once the bean is broken, the intense rich flavor begins to deteriorate.

If using the blade-type coffee grinder, shake it occasionally during grinding to redistribute the whole beans for a more uniform grind. Experiment to find the right grind for your coffeemaker and taste. If the beans are ground too finely it will produce a bitter taste; if ground too coarsely the coffee will taste weak and watery.

Some specialty coffees recommend using more than one tablespoon of ground coffee per cup. Your new coffeemaker is designed to brew good

quality coffee using less amounts of ground coffee. One level tablespoon of ground coffee per cup is recommended. Of course, the amount of ground coffee used depends upon your personal preference.

The quality of your drinking water will affect the flavor of your coffee. If you do not drink water straight from the tap, do not use it to make coffee. If your water has an off taste or smell, or if you have extremely hard water, use bottled drinking water or filtered water to make coffee. If the water is from the tap, it should be freshly drawn and cold for the best coffee flavor.

The amount of coffee to water depends upon personal preference. One tablespoon of ground coffee per cup is recommended.

Automatic coffeemakers generally use a 5 ounce cup size. The coffeemaker's carafe and reservoir are marked in "cups" for easy measuring.

Coffeemaker Features

Pause 'N Serve

This feature allows you to pour a cup of coffee before the entire brew cycle has completed. By removing the carafe, the flow of coffee from the bottom of the filter basket will stop.

CAUTION: The carafe should be replaced within 20 seconds. The flow of coffee will resume when carafe is returned to the Keep-Hot Plate.

Automatic Shutoff

The Automatic Shutoff feature shuts off the Keep-Hot Plate 2 hours after brew cycle begins. Always turn coffeemaker OFF and unplug when finished.

10-Cup Removable Water Reservoir

Wash before first use. Hand wash or place in top rack of household automatic dishwasher. The 10-cup reservoir can be removed for easy filling or occasional washing. Simply flip open reservoir cover and raise the removable reservoir handle. Lift out the removable reservoir and fill with water to desired level. Carefully place removable reservoir back into the coffeemaker's reservoir. Make sure the removable reservoir is fully seated for proper water flow. When using the removable reservoir it is only possible to make a 10 cup pot of coffee, as the water level marks indicate. To make a full 12 cup carafe remove the removable reservoir and fill the coffeemaker's reservoir.

Cleaning Your Coffeemaker

To Clean the Inside of the Coffeemaker

NOTE: To prolong the life of your coffeemaker, periodic cleaning is recommended. In areas with hard water more frequent cleaning is necessary.

1. Place empty carafe on Keep-Hot Plate and drop the empty filter basket into the coffeemaker. Firmly close the filter basket holder.
2. Pour one pint of plain white vinegar into the reservoir.
3. Plug unit into electrical outlet and turn ON.
4. After 30 seconds turn OFF.
5. Wait 30 minutes to allow the vinegar to clean. Then turn ON again. When the brew cycle is finished, turn OFF.
6. Empty carafe and rinse. Pour one carafe of cold tap water into the reservoir. Place carafe on Keep-Hot Plate.
7. Turn ON. When the brew cycle is finished, empty the carafe. Repeat this process with one more carafe of cold tap water.
8. Turn OFF when complete.
9. Wash carafe and filter basket before making a beverage.

To Clean the Coffeemaker Parts

1. Unplug coffeemaker and allow to cool before cleaning.
2. Wipe keep-hot plate with a clean, damp cloth. Do not use abrasives.
3. Occasionally wipe the water spreader area, located above the filter basket, with a clean, damp cloth.
4. To remove the carafe lid, push the hinge part of the lid to one side, then gently but firmly push down the other side. The pin will release from the hinge. Then remove lid.
5. The carafe, carafe lid and removable filter basket may be washed in the top rack of household automatic dishwasher or in hot, soapy water. Rinse and dry. The filter basket holder is not a removable part.
6. To remove stains on the carafe, scrub with baking soda or a mild cleanser. For hard to remove stains, fill the carafe with hot tap water and add 2 tablespoons of automatic dishwasher detergent. Let this sit overnight, then wash and rinse.
7. All other outside surfaces of the coffeemaker can be cleaned with a clean, damp cloth.

Carafe Safety Precautions



This symbol alerts you to the potential danger for personal injury if you fail to read and follow these safety precautions.



This symbol reminds you that glass is fragile and can break which could result in personal injury.

- Do not use a cracked carafe or a carafe having a loose or weakened handle.
- This carafe is designed to be used only on the Keep-Hot plate of your coffee-maker. Do not use on a gas or electric rangetop, or in a microwave or conventional oven.
- To avoid breakage, handle carafe with care. Avoid impact. Glass will break as a result of impact. Use care when filling with water to avoid hitting faucet.
- Do not place hot carafe on cool or wet surface. Allow to cool before washing or adding liquids.
- Do not set empty carafe on a hot heating surface.
- Do not clean with steel wool pads, abrasive cleanser or any other materials that may scratch.
- Do not place hands inside carafe. When handling, be careful if wearing any hand jewelry, especially diamond rings. Jewelry can scratch the glass, which increases the possibility of breakage.
- Do not bump, scratch, or boil dry.
- Discard carafe if it is cracked, scratched, or heated while empty for an extended period of time.
- To avoid accidents, do not pour in the direction of people.
- If stirring in the carafe, use only wooden, plastic, or rubber utensils. Do not use metal utensils.
- Follow the above safety precautions carefully to avoid serious burn injuries which may result if breakage occurs while carafe holds heated liquids.

Troubleshooting

Most questions you may have about your new coffeemaker can be easily answered. This handy guide lists some common coffeemaker problems and tells you how to correct them. If you need further assistance, please call our toll-free customer service number listed on the front cover of this booklet, and found on the back of the coffeemaker.

QUESTION	ANSWER
Doesn't brew or won't heat.	<ul style="list-style-type: none">• Check to be sure power cord is firmly plugged into a live power outlet.• The automatic shutoff feature turns the coffee-maker off two hours after making the coffee. Turn coffeemaker ON.
Filter Basket or Pause 'N Serve overflows.	<ul style="list-style-type: none">• Excessive amounts of ground coffee will clog the filter basket. We recommend one level tablespoon of ground coffee per cup.• Make sure coffee is not ground too finely. This will clog the filter. Permanent filters are more likely to clog than paper filters.• Be sure to use a good quality cupcake or basket style filter. The sides of the filter should be upright against side of filter basket to avoid filter collapsing.• When using Pause 'N Serve, hot water continues to flow into the filter basket and may overflow if the carafe is not returned to the Keep-Hot plate within 20 seconds.• Make sure that carafe is fully seated on the keep-hot plate.• Filter basket holder must be securely closed.
Longer than normal brew time.	<ul style="list-style-type: none">• Mineral deposits can build up in the pump of your coffeemaker. We recommend periodic cleaning of the inside of your coffeemaker. More frequent cleaning may be necessary, depending upon the hardness of your water. See "To Clean the Inside of Your Coffeemaker."• If using the removable reservoir, make sure the O-ring on bottom is attached and reservoir is firmly seated in coffeemaker's reservoir.

Customer Service

If you have a question about your coffeemaker, call our toll-free customer service number. Before calling, please note the model, type, and series numbers and fill in that information below. These numbers can be found on the bottom of your coffeemaker. This information will help us answer your question much more quickly.

MODEL: _____ **TYPE:** _____ **SERIES:** _____

TWO-YEAR LIMITED WARRANTY

Hamilton Beach/Proctor-Silex, Inc. warrants this appliance to be free from defects in material and workmanship for a period of two (2) years from the date of original purchase, except as noted. There is no warranty with respect to the following, which may be supplied with this appliance: glass parts, glass containers, cutter/strainer, nonstick soleplate and/or nonstick cooking surfaces. This warranty extends only to the original consumer purchaser and does not cover damage from abuse, neglect, or any other use not found in the printed directions. HAMILTON BEACH/PROCTOR-SILEX, INC. EXPRESSLY DISCLAIMS ANY AND ALL IMPLIED WARRANTIES, INCLUDING WARRANTIES OF MERCHANTABILITY AND FITNESS FOR A PARTICULAR PURPOSE. ANY LIABILITY HEREUNDER IS EXPRESSLY LIMITED TO THE REPAIR OR REPLACEMENT OF A DEFECTIVE PRODUCT OR AN AMOUNT EQUAL TO THE PURCHASE PRICE PAID THEREFOR, AND ALL CLAIMS FOR SPECIAL AND CONSEQUENTIAL DAMAGES ARE HEREBY EXCLUDED. Some states or provinces do not allow this exclusion or limitation of incidental or consequential losses, so the foregoing disclaimer may not apply to you. If you have a claim under this warranty, DO NOT RETURN THE APPLIANCE TO THE STORE! Please call our CUSTOMER SERVICE NUMBER. (For faster service please have model, series, and type numbers ready for operator to assist you.)

CUSTOMER SERVICE NUMBERS

In the U.S. 1-800-572-3331

In Canada 1-800-267-2826

Web site address: www.commercial.hamiltonbeach.com

KEEP THESE NUMBERS FOR FUTURE REFERENCE!

This warranty gives you specific legal rights, and you may also have other legal rights which vary from state to state, or province to province.

HAMILTON BEACH ♦ PROCTOR-SILEX, INC.

263 Yadkin Road
Southern Pines, NC 28387

PROCTOR-SILEX CANADA, INC.

Picton, Ontario K0K 2T0

840073500

Web site address: www.commercial.hamiltonbeach.com

8/00